

IoT BASED CURRENT MEASUREMENT SYSTEM FOR DISTRIBUTION TRANSFORMER SUBSTATION USING ROGOWSKI COIL CURRENT SENSOR

*Adelokun C. A¹, Iloh J.P², Okoye J.A.³ and Achebe P.N⁴

¹Postgraduate Student, Department of Electrical/Electronic Engineering, Chukwuemeka Odumegwu Ojukwu University, Uli Campus, Anambra State, Nigeria.

^{2,3,4}Department of Electrical/Electronic Engineering, Faculty of Engineering, Chukwuemeka Odumegwu Ojukwu University, Uli, Anambra State, Nigeria

*Corresponding author: ca.adelokun@unizik.edu.ng

ABSTRACT

Monitoring of transformer substations in the Nigerian power distribution network is largely done by manned intervention. Outages due to possible fault conditions are only taken account of when reported by customers or discovered through patrol visits. This results in huge logistics and maintenance costs in addition to avoidable downtimes. To address this problem, this study focused on the development of an IoT-based current measurement system for real-time measurement and remote monitoring of load current at a distribution transformer substation. Rogowski coil was adopted as the current sensing device mainly due to its advantage of non-invasive installation method, wide and dynamic range of operation, no ferromagnetic material eliminating magnetic saturation. The coil was characterized through an experimental method. A 300kVA distribution transformer located at the Enugu Electricity Distribution Company (EEDC), Awka Business District Office was used for the experiment. A rogowski coil, high precision digital multimeter and clamp-on ammeter were used to carry out the experiment. Current variations were measured and the corresponding voltage output of the rogowski coil were obtained. The results were used to model the characteristic equation used for programming the ESP8266 microcontroller with inbuilt Wi-Fi-enabled feature. The ThingSpeak platform was used as the web interface for real-time remote monitoring of the transformer load current. The results showed that the system accurately measured the transformer load current and relayed measured values to the ThingSpeak dashboard with errors within $\pm 5\%$. The study revealed the potential of rogowski coil-based IoT system for modernizing transformer substation monitoring. Such a system can be used to upgrade transformer substation monitoring systems in the Nigerian power distribution sector.

Keywords: Rogowski coil, ESP8266, Internet of Things, Wi-Fi, ThingSpeak.

1.0 INTRODUCTION

Failures of distribution transformer substations in Nigeria are usually caused mainly by variation in different transformer parameters such as, Load current, Moisture in oil which is a measure of the humidity content of the transformer cooling medium, dissolved gas in oil, bushing condition, oil level. For ages, utility companies have solely relied on manual personnel monitoring for observing the activities on their transformer installations. This approach however suffers the inherent human failure of late fault detection, where destructive damages must have been caused before arrival of personnel, this usually leads to shutting down of transformers. With the advent of technology, Supervisory Control and Data Acquisition (SCADA) systems have been proposed and partially implemented for remote monitoring of transformers installation in sub-transmission stations. However, due to obvious challenges of cybersecurity threats, complexity, cost and integration challenges; SCADA has not been implemented on consumer substations and therefore the traditional human monitoring still persists (Anthony *et al*, 2021). Therefore, there is the need for IoT based wireless monitoring.

For the current measurement system, several methods exist; the use of current transformer (CT) which is an invasive method, direct meter measurement, the use of electronic sensors like ACS712 etc.; but in this research, the use of Rogowski coil was proposed and implemented. This is a non-invasive means of measuring current around any conductor. Rogowski coils are a powerful tool for measuring current in transformers, offering several advantages over traditional CTs. Some of the advantages are: Rogowski coils are non-invasive i.e. They can be clamped around the conductor without interrupting power flow, unlike CTs which require breaking the circuit for installation. This makes them ideal for high-voltage or energized circuits as the case under examination here. They also have wide dynamic range, i.e. they can accurately measure currents over a wide range, from milliamps to thousands of amps, making them suitable for various applications, they have linear response, that is; they have a linear output proportional to the current, regardless of the frequency or waveform, which enables accurate measurements even for distorted waveforms, fast response due to their low inductance, making them suitable for monitoring transient currents and harmonics, Small size and weight; they are typically smaller and lighter than CTs, making them easier to install and handle and have strong immune to saturation; they are not susceptible to magnetic saturation, which is a major concern with CTs at high currents. (Jo, 2014). For the obvious advantages above and many others offered by rogowski coil, it therefore becomes pertinent to begin the full implementation of Rogowski coil as a tool for measuring and monitoring sub-station transformer.

Over the years, distribution sub-station transformers in Nigeria have been experiencing incessant failures and breakdowns due majorly to over-current at their secondary terminals. With numerous transformers distributed over a wide area in modern electrical systems, manual monitoring of each one is impractical. Therefore, an IoT-based distribution transformer current measuring system is required, this was what birthed this research. The core objectives of the research were: to select a suitable Rogowski coil current sensor through field test at a live transformer substation, develop and build the current measuring device using the Wi-Fi enabled microcontroller ESP 8266, develop the firmware for driving the measuring device hardware and connecting it to Wi-Fi hotspot for internet access and finally to do performance evaluation of the developed system.

2.0 SUMMARY OF RELATED WORKS

Various attempts have been made by several researchers to design IoT based current measurement system suitable for metering electric power consumption. Presently, the majority of them have been focused on the conventional current transformer as the sensor which is an intrusive and bulky type of sensors as compared to rogowski coils. The few related literature on this interesting area is thus presented here.

Anthony *et al* (2021) proposed an IoT system for transformer monitoring using low-power wireless sensors and a cloud platform for data visualization and analysis. The study developed an IoT based transformer monitoring using open-source software, modular and low-cost components. Arduino Mega 2560 microcontroller was used as the main component in the system. The system can acquire data from a wide variety of sensors using internal and external transducers. And this data can be saved to the cloud system synchronously with the memory card on the monitoring system. The developed monitoring system has been utilized free on reliable platforms such as the Thing Speak web interface and Pushing Box Notification application. The test process of the developed monitoring system was carried out in the laboratory environment on a prototype transformer.

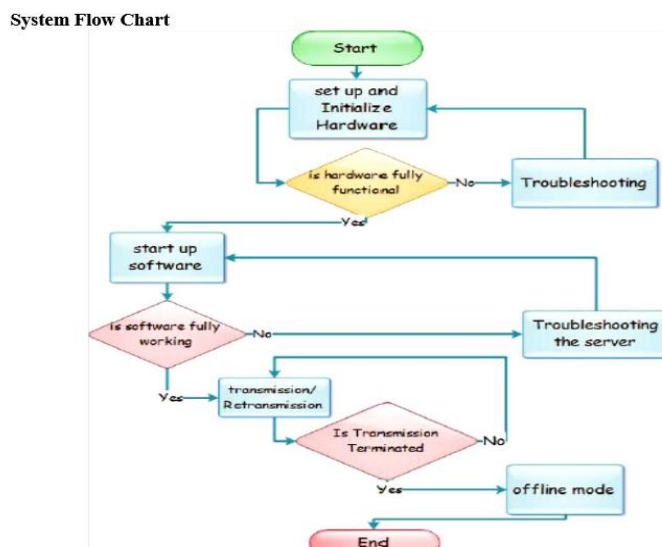

Figure 1: Overall system flow chart of the system

The flow chart of the system is illustrated in Figure 1. The results presented in the work showed that the parameters of the object transformer can be remotely monitored and data sent remotely to dedicated desk engineers to take necessary action when the threshold set by the system designer has been exceeded. However, the major drawback of this design was that it still depends on the conventional current transformer which poses danger to installers as this is an intrusive type of measurement. Also, the system suffers magnetic saturation as this is the major setback of current transformer.

In Ajitha *et al.*(2017), A new IoT framework for condition monitoring and controlling of larger number of distribution transformers were proposed and developed using LoRa (Long-range) technology for monitoring and diagnosing the condition of distribution transformers using specified sensors/devices. key operation indicators like voltage, load current, winding temperatures, oil temperatures, oil level in conservator and breather silica gel status of each distribution transformer in the range of 10km using LoRa modules were

facilitated. These data were sent to IoT platform using LoRa gateway. From the report, if a parameter of any distribution transformer exceeds the predefined value/level, alerts will be received on the developed web application showing the particular transformer's location, to take necessary action. Commands of controlling transformer's operation can be issued from the web application itself.

In Iloh. (2020), Rogowski Coils for Design of Energy Meters for Nigeria Power Market was developed. The work set out to develop an energy meter design that is affordable, efficient, reliable and has significant local content in its value chain; locally wound rogowski coil was introduced as alternative to the conventional current transformer as sensing element. Two rogowski coil samples wound from SWG 36 and SWG 25 wires having resistances of 50ohm and 1.3 Ohms respectively were subjected to repeated experimental tests in order to study their characteristic behavior under varying load current scenarios. The results obtained were used to characterize the coils behaviors by using the basic fitting tool in MATLAB graphing window to generate the optimal equation representing the coils' behaviors. The equations obtained were used to program the microcontroller for implementation of the Digital Energy Meter algorithm adopted in the proposed design. Results from the experiment showed that the coil with lower resistance exhibited better linear response while the coil with higher resistance was better optimized by quadratic and cubic polynomials. The findings of the research could serve as design guide for local fabrication of the rogowski coils to be used in the proposed digital energy meter being developed for the Nigerian power market.

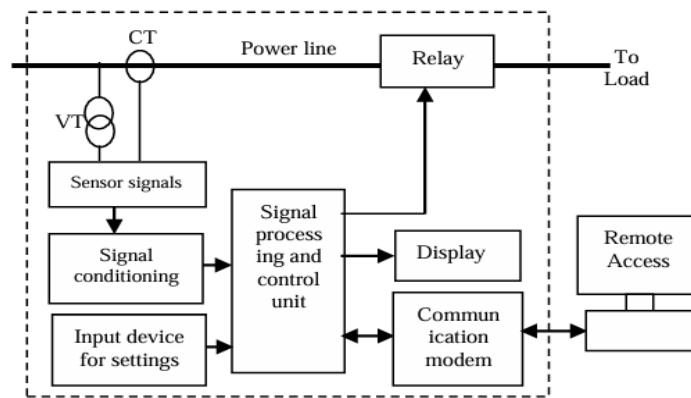

Figure2: Block diagram of the proposed

The block diagram of the designed system was shown in figure 2. Results from the experiment showed that the coil with lower resistance exhibited better linear response while the coil with higher resistance was better optimized by quadratic and cubic polynomials. These findings serve as design guide for local fabrication of the rogowski coils to be used in the proposed digital energy meter being developed for the Nigerian power market.

Sachan. (2020), presented IoT Based Transformer Parameter Monitoring. The work used sensors connected to microcontrollers employed for the purpose of collecting the various parametric data from the object transformer. The recorded data were sent using a GSM/Wi-Fi module and accessed using IOT technology from any location in the world. The system architecture was designed using a microcontroller board AVR Atmega328, which was programmed to collect sensor data and send it over a wireless network. Sensors for measuring transformer parameters such as current, voltage, temperature, and oil level were selected based on the specifications of the transformer to be monitored. For measuring the oil temperature, a temperature sensor LM35 was used while ultrasonic sensor HC -Sr04 was selected for measuring the oil level. The result showed

that the recorded data can be sent using a GSM/Wi-Fi module and accessed using IOT technology from any location in the world. This aids in identification without reliance on people. This assists in spotting and fixing issues before they become failures without human supervision.

3.0 METHODOLOGY

A Materials

An imported rogowski coil manufactured by Eaton was used. It was a 16 inches long with window size of 4 inches, a high precision digital voltmeter, clamp-on meter, digital storage oscilloscope were all used with access to a live transformer at EEDC Awka business premises.

B. System Block Diagram

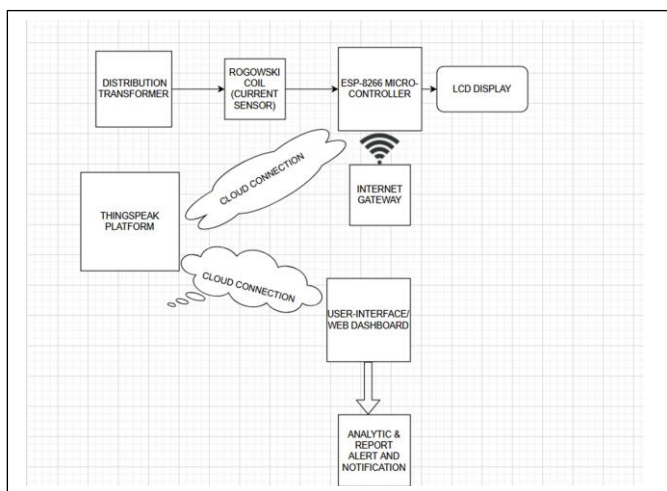

Thus, based on the concept presented in the block diagram of figure 3, the hardware and software systems for the IoT ammeter was developed. The functions of the various blocks are briefly explained as follows.

Figure 3: System Block Diagram

Distribution Transformer: This is the test object. It was the transformer chosen based on the locality of the researcher. It is 300kVA step down substation transformer, located at the premise of the power Holding Company of Nigeria, Awka business premise.

Current Sensor. This is the rogowski coil chosen for this study. It produced voltage derivative of the current flowing in the conductor it encircled.

Microcontroller ESP8266. This is the chip used for the programming of the functionality of the system. It has analog input and ADC to convert this to digital inputs, it has also WIFI capability thus making it suitable for this work.

LCD Display: this helped to physically read out the measured current on site.

ThingSpeak Platform: This is the internet web page platform employed for this research. It offers free cloud database, data storage and visualization options among other. Here the system used the popular Thingspeak platform. Services offer here include web dashboard and analytics plus alert notification.

C. System Design Specification

The designed system should measure substation transformer secondary coil current of up to 450A (based on the 300KVA size of the substation transformer. So, this value of current capacity informs the size of the Rogowski coil to be used. This value of current was chosen as baseline, so that the system could withstand full load current of the object transformer. Equation 1 was used to obtain maximum load current of the transformer

$$I = kva * 1000 \div \sqrt{3} * V \tag{1}$$

Where I is the full load current of the transformer, V is the three phase voltage of the transformer(415v) and kVA is the rating of the transformer

With transformer rating of 300kva, I thus become;

$$I_{fl} = (300 * 1000) \div 1.732 * 415 = 417A \tag{2}$$

So, the baseline of 450A was adopted to cater for worst case load scenario

The size of a Rogowski coil for substation transformer current measurement depends on several factors like current rating, aperture (window size), physical constraint. For this system and the physical assessment of the test station sites, the size of the Rogowski coil chosen for this work was the Eaton CS-16-4-1000-RC PXM 1000 16-inch long rogowski coil with 4-inch window calibrated for 5 -1200 A. this was carefully chosen bearing in mind that the chosen microcontroller(ESP8266) has a limited voltage handling capacity of 3.3v, from the catalogue of the rogowski coil, this particular coil give an output of 120mV at 60Hz frequency and 100mV at 50Hz frequency. This low voltage makes it suitable for the operation.

Table 1: catalogue of the rogowski coil (courtesy: eaton.com)

Catalog	Output/1000A @50Hz	Output/1000A @ 60Hz	Calibrated range with PXM meters ²
CS-xx-x-1000-RC	100mV	120Mv	5A-1200A
CS-xx-x-2500-RC	40mV	48Mv	12.5A-3000A
CS-xx-x-5000-RC	20mV	24Mv	25A-6000A
CS-xx-x-12000-RC	8.3mV	9.9Mv	60A-14400A
CS-xx-x-50000-RC	2mV	2.4mV	250A-60000A

Notes:xx-x denotes coil length-window size

D) Sensor calibration (characterization of the coil)

The coil was used to measure different load current on the chosen transformer; its values was compared with the standard clamp on ammeter and the results obtained were presented as shown in table 3.

Table 2: the Rogowski coil output voltage(mV) against Transformer load in Ampere

I_t (A)	V_{rc} (mV)
73	21.0
76	23.6
81	22.7
84	20.6
87	25.0
92	22.5
92	22.0
96	23.0
100	25.6
101	24.7
104	26.6
135	35.0
136	37.1
139	37.6
142	38.3
144	39.2
166	43.0
157	41.8

Table 2 depicted the variation of the transformer current with the voltage response of the rogowski coil. The results obtained from this showed a reasonable linearity and was used to characterize the coil’s behaviour using the basic fitting tool in excel graphing window. Figure 4 showed the plot obtained and the equation formed.

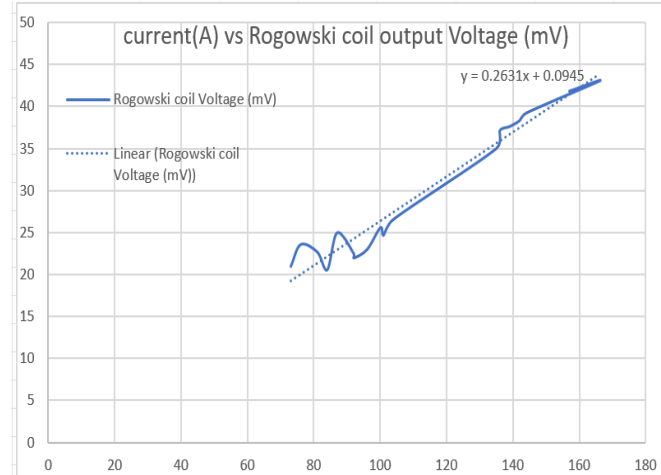

Figure 4: graphical representation of transformer load against the coil’s output voltage response

From the graph of figure 4, the characteristic equation of the coil was modelled using the excel application interface. The equation modelled was presented in equation 7

$$y = 0.2631x + 0.0945 \tag{3}$$

From equation 3, we proceeded by modelling a general equation for the transformer current reading by the coil simply by mathematically manipulating equation 3 and making ‘x’ (the transformer load current) the subject.

thus,

$$x = (y - 0.0945) \div 0.2631 \tag{4}$$

With ‘I’ replacing x in the equation 4 earlier, because this is a more related symbol for electric current, the transformer currents I is thus shown in equation 5

$$I = (y - 0.0945) \div 0.2631 \tag{5}$$

Where y= coil’s output voltage and I is the resulted measured transformer current. Equation 5 was what produced the result in table 4.

Table 4: table of the result obtained from the modelled equation

Actual reading	coil voltage	modeled	Error	%Error
73	21	79.4583808	-6.4583808	-8.847097
76	23.6	89.3405549	-13.340555	-17.553362
81	22.7	85.9198024	-4.9198024	-6.0738301
84	20.6	77.9380464	6.0619536	7.21661146
87	25	94.6617256	-7.6617256	-8.8065811
92	22.5	85.1596351	6.8403649	7.43517922
92	22	83.259217	8.740783	9.50085106
96	23	87.0600532	8.9399468	9.31244457
100	25.6	96.9422273	3.057727	3.0577271
101	24.7	93.5214747	7.4785253	7.40448047
104	26.6	100.743063	3.2569365	3.13166974
135	35	132.670087	2.3299126	1.72586117
136	37.1	140.651843	-4.6518434	-3.4204731
139	37.6	142.552261	-3.5522615	-2.5555838
142	38.3	145.212847	-3.2128468	-2.2625682
144	39.2	148.633599	-4.6335994	-3.2177774
166	43	163.076777	2.9232231	1.76097778
157	41.8	158.515773	-1.5157735	-0.9654608

From the modelled table 4, it was observed the system produced error of less than 10%. This level is an acceptable value for this study and therefore the calibration was accepted with the intent to flatten the error curve using the offset level of the microcontroller.

E Firmware Development

Programming the microcontroller (ESP8266) for current measurement

The output from the rogowski coil was fed to the LM358 based integrator and amplifier circuitry to produce an amplified current derivative of the coils output voltage. The output from integrator was then fed to the analog input(A0) of the ESP8266 as shown in the circuit diagram of figure 5

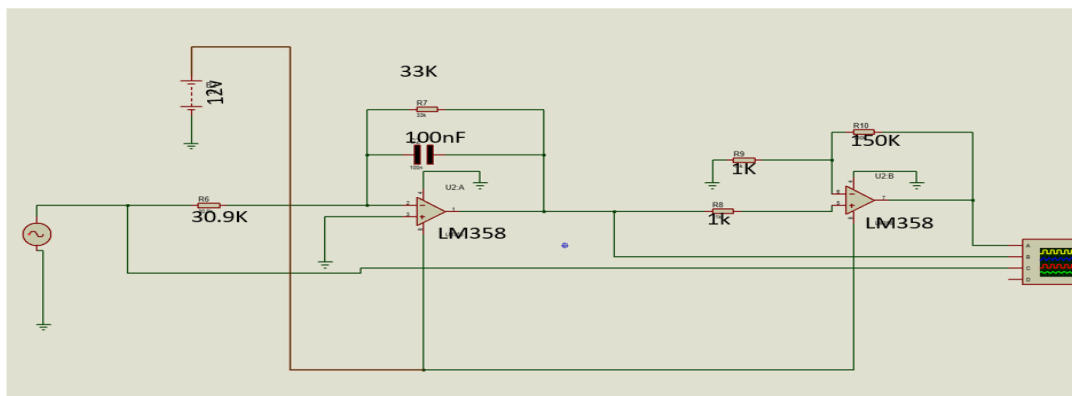

Figure 5: Fast Settling circuitry for amplification and integration of the rogowski coil output.

F Design Calculation for the Integrator circuit

For the integrator circuitry, the formular presented in equation 6 was used for the integrator circuit,

$$V_{out} = 1/RC \int V_m(t) dt \tag{6}$$

The parameters of the chosen rogowski coil were

Sensitivity: 10mV per 1000A at 50 Hz (or 10 μV/A)

Maximum primary current: 500 A r.m.s

Output voltage at max current: 500 A × 10 μV/A = 5 mV (peak)

While the desired output voltage the ESP8266 can handle was: 0–3.0 V range (from the database of ESP8266)

Target frequency: 50 Hz (T = 20ms)

Ideal Op-amp integrator time constant=1/(2πf)

Using $\tau = 1/2\pi f$ we determined the time Constant

$$\frac{1}{2\pi \times 50} = 3.18ms$$

Choosing a standard value of C to be 0.1uF (100nF)

$$\tau = RC$$

$$3.18 \times 10^{-3} = R \times 100 \times 10^{-9}$$

R=31.8kohm. the nearest standard resistor of 33kohm was then chosen

G. Setting up the Cloud Interface on the Thingspeak Platform

To achieve the cloud integration feature of the system, an account was created on the Thingspeak platform at <https://thingspeak.com>, there account was created using the researcher’s email and password. This is presented in figure 6.

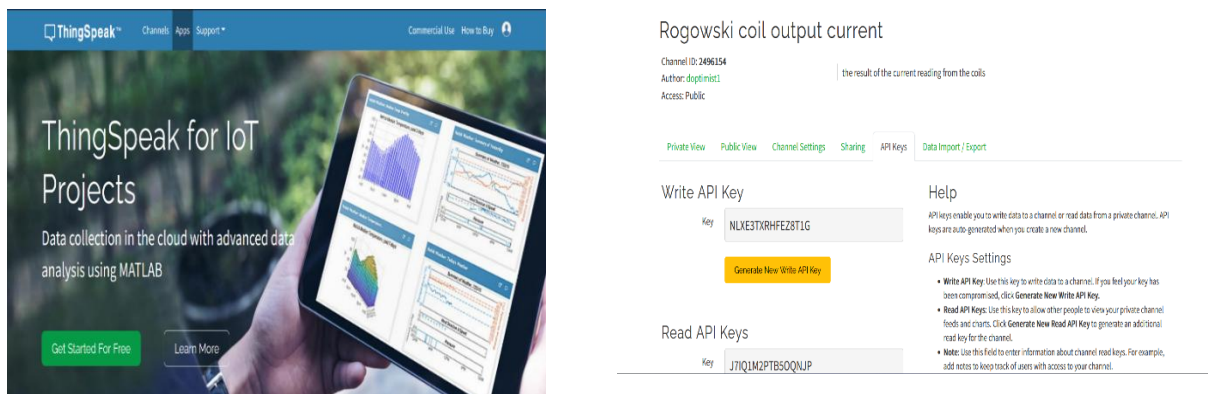

Figure 6: the Thingspeak interface and the application programming Interface used for linkage of the ESP8266 to the cloud.

A new channel was thereafter created with two fields as “Current” and ADC voltage. From the dashboard on the Thingspeak website, Application programming Interface (API) code was provided and this was copied. The copied API was taken back to the Arduino IDE, where Thingspeak library and ESP8266 Wi-Fi libraries were installed and the API copied from the Thingspeak pasted. service state identifier (SSID), password, channel number were set and the channel become active. The Thingspeak gives live updating chart of the current “A” over time. It also comes with downloadable CSV file which can be integrated with MATLAB for analysis and alerts. The lines of code used on the Arduino platform has been attached to the appendices section of this work.

The complete circuit diagram of the entire system has been presented in figure 7. As shown in the figure, the microcontroller ESP 8266 was the chief component, which accepted the integrated and amplified signal through its only analog input A0, digitized the signal through its internal analog to digital converter (ADC), and then process it via the program written into it on IDE environment using the modelled equation earlier. The current transformer current equivalent of this processed signal is printed out via the LCD, virtual monitor of the IDE and also published into the Thingspeak web interface.

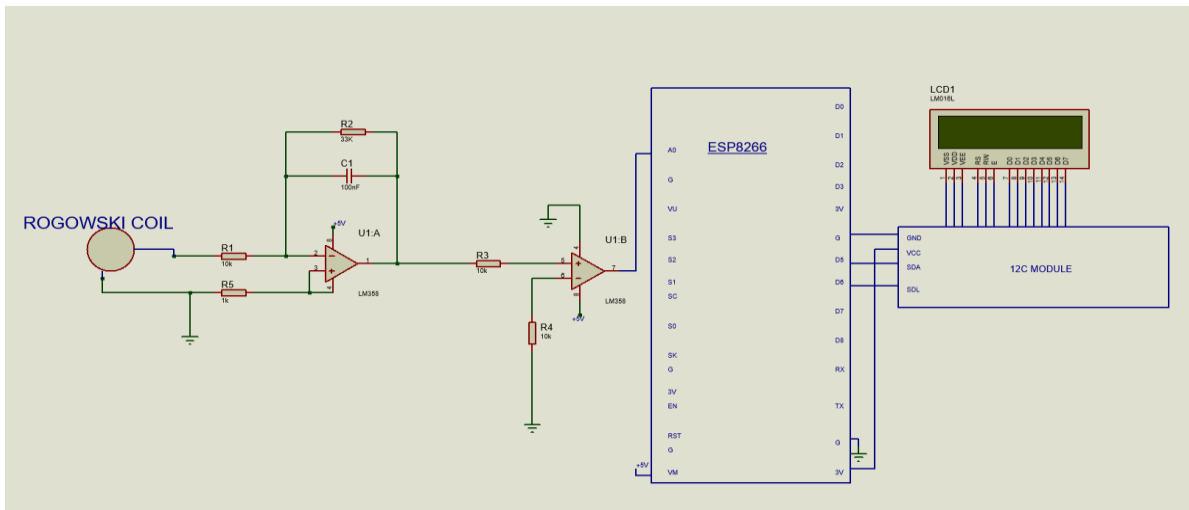

Figure 7: complete circuit Diagram of the system

4.0 RESULTS AND DISCUSSION

A Fast-settling circuitry (for Amplifier and Integrator Section) Result

As earlier presented in the circuit diagram of figure 7, to achieve the amplifier and integration of the coil's output. The two Opamp(s) were connected as shown. The coil's highest output voltage signal was modelled on the proteus simulation software using the function generator and fed to the integrator circuit, the output from the integrator was fed to the amplifier in order to boost the signal. Three measurements were taken from the simulated result. One before the integrator (colour green on the simulation scope, the second after the integrator circuit (colour red on the simulation graph) while the third was taken after the integrated output was amplified by the second Opamp.

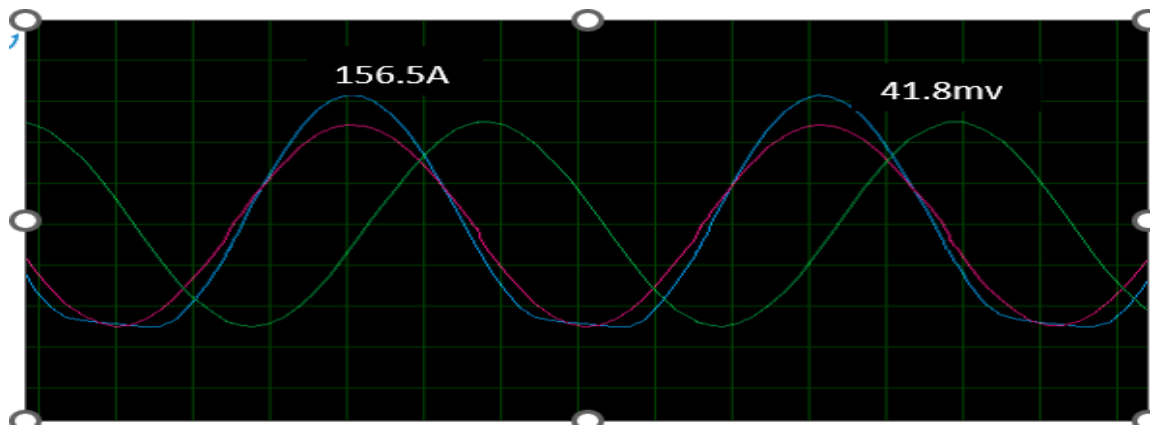

Figure 8: simulation result for fast settling circuitry

The output waveform of the three different test level carried out is presented in figure 8. From the waveform, it was observed that the un-integrated signal (shown in green) was amplified and phase corrected with the combination of the integrator circuit and the amplifier circuit. Note how the waveform in red and blue are bigger and have their phase aligned when compared to the green waveform. This showed that the amplifier circuit has amplified the signal and also the integrator circuit successfully produced the derivative of the

voltage. the signal was measured and fairly corresponded to the transformer currents that produced the coil's voltage.

B Cloud Platform Results

After the whole system set-up, the cloud platform was accessed to observe the visibility of the interface. The block diagram of the Thingspeak platform is shown in figure 9 the different IoT devices were connected to the platform, while the platform has a backend connection to the MATLAB platform for algorithm development and analytics.

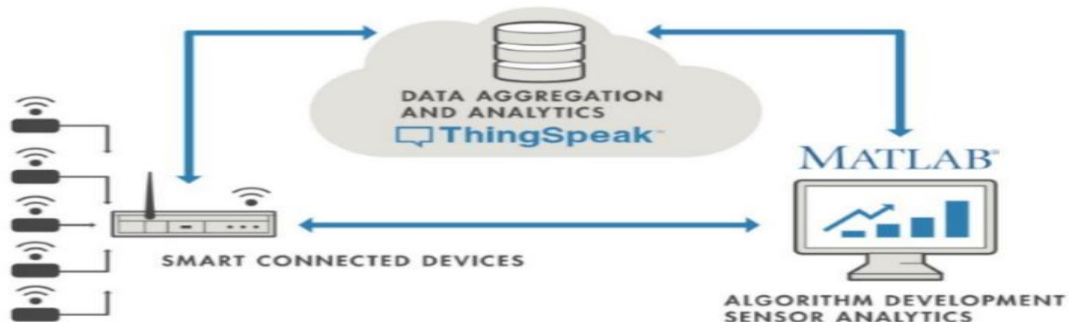

Figure 9: Block diagram of Thingspeak platform for IoT projects

The channel created earlier in this work was then accessed via the cloud platform, after the developed system has been connected to the object transformer secondary conductor, and the initial Wi-Fi set up has been done via the researcher's mobile network. The channel became life with two fields. The first field showed the current in the transformer phase while the second field showed the ADC voltage that produced the results. This result has been presented in figure 10



Figure 10: Channel developed on the Thingspeak platform for the cloud operation of the system.

As depicted in the figure 10, the channel consists of main interface or field: the filed one chart showed, at every instant the current measured by the deployed system at the selected substation transformer. This was virtually displayed on the Thingspeak platform upon successful login through the provided credentials as long as the device is connected to the internet. In the same manner, the second field, showed the ADC-voltage output of the rogowski coil in a chat form.

By careful monitoring of the virtual data displayed, it was observed that the system almost accurately reproduced the transformer current with little error. Figure 11 showed an instant where the ADC voltage was

26.6mv and transformer current of 104A, these values closely matched with the values of the table of the coil's calibration earlier presented.

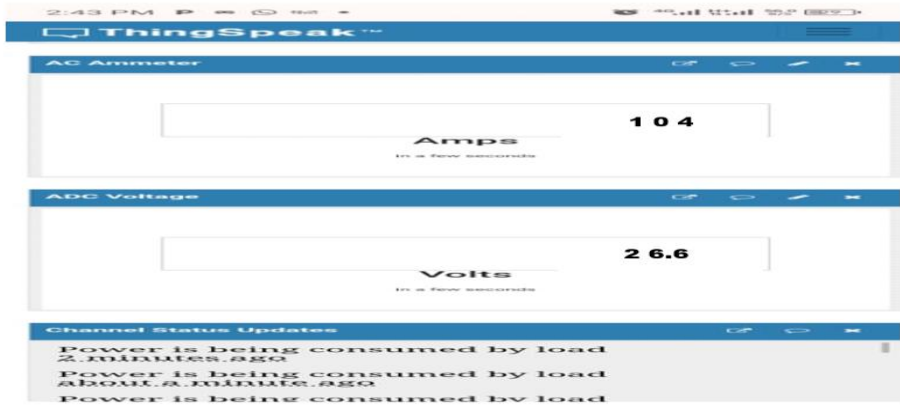

Figure 11 real-time current sensing and cloud updating of the system

As observed from the figure 11, the system was able to monitor real-time current and update the same to the Thingspeak cloud platform. The frequency of update was set at 10seconds, which means the system was designed to detect any overshoot of current and send notification to user or designated persons within acceptable time limit thereby preventing overcurrent.

Finally, the completed design prototype of the system as shown in the plate 1 while plate two showed the nameplate of the object transformer. the system was incorporated with a display which allows for physical inspection at the site station in the event that one don't want to rely on the cloud generated figures.



Plate 1: Complete prototype of the system

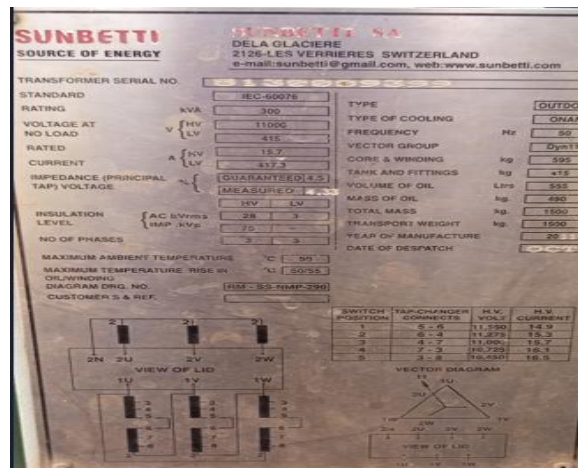

Plate 2: The Nameplate of the chosen transformer

5.0 DISCUSSIONS

The implemented IoT-based current measurement system demonstrated a reliable and non-intrusive method for monitoring transformer load currents in substations. The use of rogowski coil allowed for safe and accurate sensing of high AC currents without direct electrical contact, making it suitable for high-voltage environments. The integrator circuit effectively translated the coil’s di/dt output into a measurable voltage signal for the ESP8266’s ADC.

A major challenge encountered was signal noise, particularly at higher frequencies. This was addressed by optimizing the RC values in the integrator and incorporating a low-pass filter to stabilize readings. Additionally, careful calibration was essential to convert ADC values into meaningful current measurements. The relatively low resolution (10-bit) and input voltage range (0–1V) of the ESP8266’s ADC posed a limitation; however, it was sufficient for general monitoring purposes. In future designs, a higher-resolution external ADC could be integrated to improve accuracy, especially at low current levels.

The integration of an I2C LCD proved useful for real-time local monitoring. Maintenance personnel could view instantaneous current readings directly at the installation site without the need to connect remotely. Meanwhile, the cloud connectivity feature enabled continuous remote monitoring and data logging. Through the Thingspeak cloud platform, current data was transmitted and visualized remotely with low latency, providing valuable insights into transformer load patterns.

One of the key benefits of this system is its scalability—multiple such units can be deployed across various transformers within a substation or even across geographically distributed substations, all feeding into a centralized monitoring dashboard. Additionally, because it operates over Wi-Fi, installation and configuration are straightforward in environments with existing network infrastructure. However, in remote areas without Wi-Fi, alternative communication modules like GSM, NB-IoT, or LoRa could be explored.

The developed system effectively combines real-time sensing, local display, and IoT-based remote access in a compact and cost-effective package. It supports enhanced monitoring, preventive maintenance, and data-driven decision-making in power distribution networks.

Conclusively, chapter four has presented quantitative and qualitative research findings addressing the four specific objectives of this thesis. Chapter five presents the conclusions, discussions and recommendations for future works.

6.0 CONCLUSIONS

This study has contributed a compact, cost-effective, and intelligent solution for current monitoring in electrical substations, thereby making way for future enhancements such as multi-phase measurement, integration with SCADA systems, and AI-based fault prediction. This study has made significant contributions to the field of power system monitoring and smart grid technologies in that it has brought Innovative Integration of rogowski coil as current sensor. It has also demonstrated a novel combination of rogowski coil sensor with IoT frameworks, overcoming limitations of traditional CT-based systems in terms of magnetic saturation issue and safety concerns. The system developed in this research has shown not prone to magnetic saturation due to the non-magnetic nature of the core of the coil. Also, the fact that it is a non-invasive current measuring instrument has made it overcome the safety concern during installation and services. The designed system has employed the use of internet based Thingspeak website platform assessable globally, so the issue of coverage limitation has been carefully overcome. Finally, this research was based on life-sub-station transformer unlike several other researches which were mainly done on miniaturized electronic transformer. Hence, the results of this study can be trusted as a framework for future studies. It is therefore suggested further works should be done to expand the system to three-phase configuration as the system developed here was limited to single phase.

7.0 RECOMMENDATIONS

This work will be beneficial and therefore recommended for remote equipment monitoring of electrical systems, **predictive maintenance and also beneficial to** Power authorities (EEDC, AEDC, Eko electric etc.) to monitor their transformer load currents. The system can thus be retrofitted to initiate action plans like remote isolation in case of over current.

REFERENCES

- Ajitha, A., Anil Kumar . (2017). Development of IOT Based Solution for Monitoring and Controlling of Distibtution Transformers. *2017 International Conference on Intelligent Computing, Instrumentation and Control Technologies (ICICICT)* (pp. 1457-1461). India: Anurag group of Institutions.
- Anthony, K., Stephen, K.O., Ben, A., Patrick, A.B., Phin, A.A., (2021). Design and Construction of an IoT Based Distribution Transformer Condition Monitoring System. *International Journal of Engineering and Science (IJES)*, 20-24.
- Boqi, X., Dongbo, Z. & Tianqi, H (2024). Transformer Monitoring and Protection in Dynamic power Systems-A review. *Frontiers in Energy Research*. 1-15.
- Bragadesh, D. (2021). business process incubator. Retrieved from Business Process Incubator: <https://www.businessprocessincubator.com/content/smart-substationintelligent-feeder-management/>

Eren, H. (2005). Handbook of Measuring System Design. Australia: Curtin University of Technology, Perth, Western Australia, Australia.

Eren, H. (2024, March 30). Research Gate. Retrieved from <https://www.researchgate.net/publication/295072837> current measurement. [Accessed Mar. 30 2024].): <https://www.researchgate.net/publication/295072837> current measurement.

Hossain, M. S., Rahman, M., Sarker, M. T., Haque, M. E., & Jahid, A. (2019). A smart IoT based system for monitoring and controlling the substation Equipment. Elsevier, 1 16. Retrieved from Elsevier: : www.elsevier.com/locate/iot

Ignacio, D. M. (2022). Internet of Things communication/. Retrieved from www.allaboutcircuits.com:<https://www.allaboutcircuits.com/technical-articles/internet-of-things-communication-protocols-iot-data-protocols/>

Iloh, J. P. (2020). Rogowski Coils for Design of Energy Meters for Nigeria. *European Journal of Engineering Research and Science*, 626-631.

Iloh, J. P., Okwu P.I, Mbachu, C.B & Anumaka M.C.(2014). Rogowski Coil Current Sensing Technology for power System Automation. *2nd International Conference on Engineering Adaptaion on Policy Reforms for Industrial Development (ICEAPR)*.

Internet of things (2024, April, 15). Oracle.com.:<https://www.oracle.com/ng/internet-of-things/what-is-iot/>).

Joao, M. (2018). Accesssing the ESP8266 WI-FI module for the Internet of things. IEEE 23rd International Conference on Emerging Technologies and Factory Automation. Torino, Italy. 124-145.

John, P. B (2014). The use of rogowski coils in current measurement. 17th International Symposium on Electromagnetic Launch Technology. Published by IEEE. La Jolla, CA, USA.

John, A.R., Varghese, S.S., Krishnan, S., Thomas, T.A., Swayambu, P. (2017). Automation of 11 kV substation using raspberry pi, in: Proceedings of the. proceeding of the international conference on circuit, power and computing technologies(ICCPCCT) (pp. 1-5). Kollam: ICCPCCT.

Kojovic, L. A. (2022). Application of Rogowski Coils used for Protective Relaying Purposes. Power Systems Conference and Exposition, 2022. PSCE '06. 2022 IEEE PES (pp. 538-543). IEEE Explore.

Low Voltage Power Distribution (2025, April,10). [eaton.com](https://www.eaton.com) <https://www.eaton.com/content/dam/eaton/products/low-voltage-power-distribution-controls-systems/power-energy-meters/power-xpert-meter-1000/r-coil-td150039en.pdf> [16] Mehta, V.K & R. Mehta. (2018). Principles of power system , 3rd edition. New Dehi India: S. Chand & Company ltd.

Medium Voltage transformer. (2024, April 04). citizen's electric company: [https://c03.apogee.net/mvc/home/hes/land/el?spc=foe&id=4469&utilityname=citizens electric](https://c03.apogee.net/mvc/home/hes/land/el?spc=foe&id=4469&utilityname=citizens%20electric).

- Pathania, S. (2019). IoT Based Distribution Transformer Health Monitoring System. Punjab, India: Tharpar Institute of Engineering Technology.
- Sachan, A., (2020). Microcontroller based substation monitoring and control system with GSM modem. IOSR Journal, 13-21.
- Shuvam, B (2019). An Internet of Things (IoT) Based System to Analyze Real-time Collapsing Probability of Structures. Conference paper uploaded on ResearchGate. https://www.researchgate.net/publication/330473118_An_Internet_of_Things_IoT_Based_System_to_Analyze_Real-time_Collapsing_Probability_of_Structures/citations
- Vahidnia, R. ,Dian, F.J.(2024, 04 05). IoT Use Cases and Technologies . Retrieved from Pressbooks: <https://pressbooks.bccampus.ca/iotbook/chapter/lpwan/>
- Vahidnia ,R. , John, F.D & Rahmati, A. (2020). Wearables and the Internet of Things (IoT), Applications, Opportunities, and Challenges: A Survey. IEEE Access journal. 69200-69211
- What is IoT. (2024, january 25). Oracle web page. Retrieved from Internet of Things: <https://www.oracle.com/ng/internet-of-things/what-is-iot/>
- Webster, J. G. (2014). Measurement, Instrumentation, and Sensors Handbook :Second Edition Electromagnetic, Optical, Radiation, Chemical, and Biomedical Measurement. India: CRC press.